

Turntable Assembly Instructions

Step-by-step assembly instructions

Copyright miniatures.com 2023

In many instances, it will not be necessary to permanently mount the turntable to the base or the object to the turntable. Most objects will create no wobble, even if the object is just placed on the turntable. This is especially true of heavier objects.

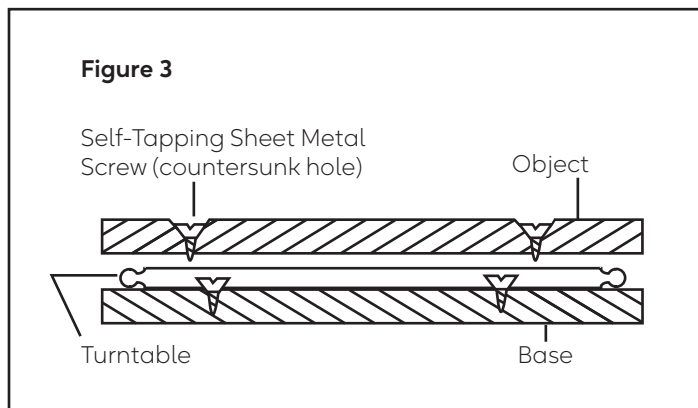
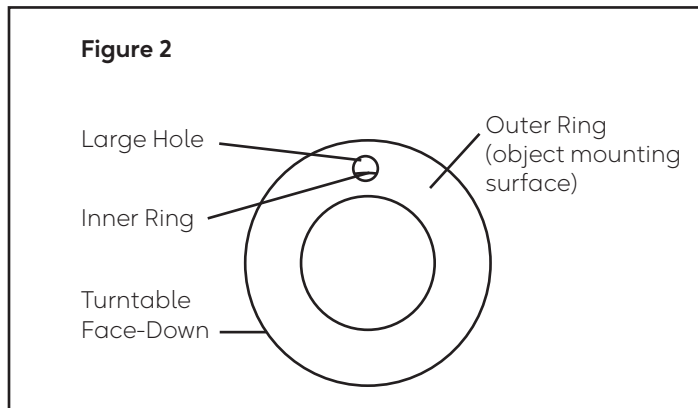
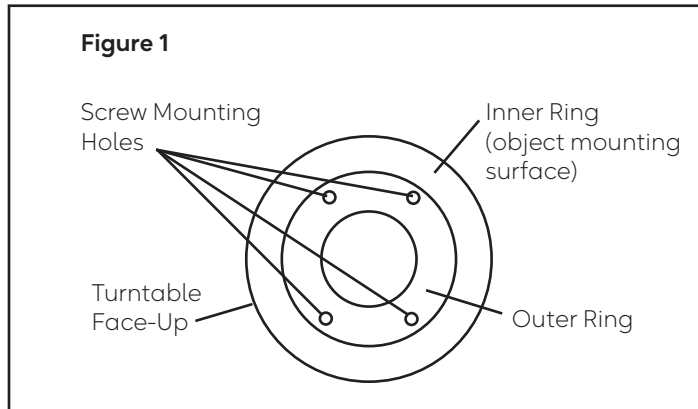

1. Turntable to Base Only

If you are simply going to mount the turntable to a base, use the following procedure:

Place the turntable on the base and screw into position using the 4 small holes on the outer ring as shown (Figure 1).

2. Turntable to Object Only

Position the turntable on the bottom surface of the object.

The inner ring, or object surface, of the turntable rests on the bottom surface of the object.

Rotate the outer ring so the large hole is over a screw-mounted hole (Figure 2).

3. Turntable to Base & Object

Place turntable, upside-down, on the surface of the object base.

Mark the locations of the four small holes of the inner ring. Remove turntable, drill and counter-sink these holes.

Install turntable to base as in step 2.

Fasten object to turntable with self-tapping sheet metal screws (Figure 3).